

GIA NATURAL COLORED DIAMOND REPORT

November 21, 2024
 Report Type Grading Report
 GIA Report Number 5232436728
 Shape and Cutting Style Oval Brilliant
 Measurements 14.91 x 7.51 x 3.72 mm

Carat Weight 3.14 carat
 Color Grade Fancy Deep Brown-Yellow
 Color Origin Natural
 Color Distribution Even
 Clarity Grade Internally Flawless
 Proportions:

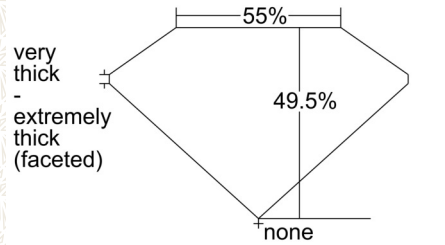

Profile not to actual proportions

Polish Very Good
 Symmetry Excellent
 Fluorescence None
 Inscription(s): GIA 5232436728

Comments: Minor details of polish are not shown.

ADDITIONAL INFORMATION

GIA COLORED DIAMOND SCALE

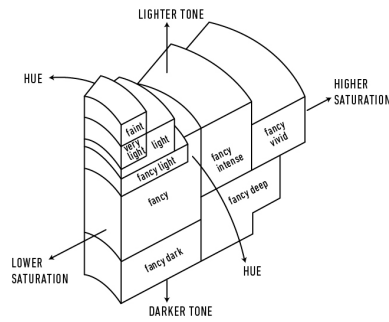
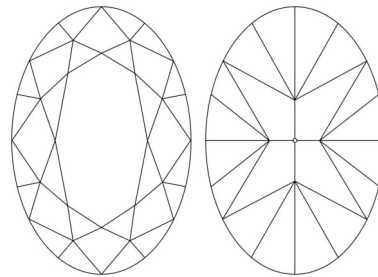

Illustration of GIA fancy color grade interrelationships

GIA CLARITY SCALE

FLAWLESS
INTERNALLY FLAWLESS
VVS ₁
VVS ₂
VS ₁
VS ₂
SI ₁
SI ₂
I ₁
I ₂
I ₃

CLARITY CHARACTERISTICS



The results documented in this report refer only to the diamond described, and were obtained using the techniques and equipment available to GIA at the time of examination. This report is not a guarantee or valuation. For additional information and important limitations and disclaimers, please see GIA.edu/terms or call +1 800 421 7250 or +1 760 603 4500. ©2023 Gemological Institute of America, Inc.

reportcheck.gia.edu



 THE SECURITY FEATURES IN THIS DOCUMENT, INCLUDING THE HOLOGRAM, SECURITY SCREEN AND MICROPRINT LINES, IN ADDITION TO THOSE NOT LISTED, EXCEED DOCUMENT SECURITY INDUSTRY GUIDELINES.